



LiFePO4 Lithium Starter battery

Model **13 - 12 R** (Ref. LITH12,3Ah)

Model **13 - 12 PR** (Ref. LITH12,3Ah-P)

INSTRUCTION, USE AND MAINTENANCE MANUAL

Revision 1 date 01/10/2011

ATTENTION !

This manual is subject to international copyright laws.

Unauthorized publication of the same, whether partial or complete, will be persecuted according to the law !

The Company reserves the right to make changes and improvements on the machine at any time and without advance notice

Distribuito da:



WWW.TECNO2.COM

Tel.+39-011.8224969 - Fax +39-011.8225073
Strada del Cascinotto 139/43 - 10156 Torino (TO) Italia
Homepage: www.tecno2.com

INDEX

Pag.

0. PREMISES.....	3
0.1. HOW TO READ AND USE THIS MANUAL.....	3
0.1.1. CONSULTING THE MANUAL.....	3
1. GENERAL INFORMATION.....	4
1.1. GENERAL SAFETY WARNINGS.....	4
1.2. BATTERY IDENTIFICATION DATA.....	5
1.3. WARRANTY.....	5
2. BATTERY FEATURES.....	6
2.1. NORMATIVE REFERENCES.....	6
2.2. TECHNICAL FEATURES AND DIMENSIONS.....	6
3. INSALLATION.....	7
3.1. PRELIMINARY PROCEEDINGS.....	7
3.2. PLACE OF INSTALLATION.....	7
3.3. CONNECTION	7
3.4. BATTERY CHARGER.....	7
4. MAINTENANCE.....	7
4.1. MAINTENANCE E/O PRESERVATION.....	7

0. PREMISES

0.1. HOW TO READ AND USE THIS MANUAL

- This manual must be considered as an integral part of the battery.
- This manual must be saved for the entire life span of the battery.
- This manual must accompany the battery whenever the same is assigned to others.

0.1.1. CONSULTING THE MANUAL

The manual has been written according to the Rules in effect. The Manual is composed by :

- A-** Identification Cover ;
- B-** Index of Chapters ;
- C-** Battery instructions.

A – Identification Cover

The cover identifies the battery to which the present Manual is dedicated. In the cover are indicated the following data :

- Builder Logo
- Battery model
- Identification code
- Editorial date
- Version

B – Chapters Index

The index of chapters numerates the subjects examined by the manual. Analytical index develops the chapters expanding the subtitles research for each subject.

C - Battery Instructions

This part of the Manual gives a detailed description of the battery working, all the operations needed in order to have a good functioning , the rules to follow for the installation , expedients and rules, battery cycle, the proceedings dedicated to Operator for service.

ATTENTION

**Being the battery of small capacity, it's necessary the charge maintaining during the off duty periods of vehicle
(see chapter MAINTENANCE)
In order to avoid the irremediable damage**

1. GENERAL INFORMATION

1.1. GENERAL SAFETY WARNINGS

With reference to the General safety rules, the efficiency of the battery must be devolved upon qualified personnel. The Builder is not responsible for damages occurred to objects or persons if caused from negligence of personnel that ignore the rules of the present Manual.

ATTENTION: The battery is supplied CHARGED and so able to supply important currents even if new. Put NEVER in short circuit the battery poles + and -.

Furthermore, the safety rules calculates the following fundamental points :

- *It's forbidden remove the battery shell.*
- *It's forbidden inhibit the safety rules that the builder installed on the battery.*
- *During the cleaning of the battery it's compulsory the interruption of all the energies connected to it.*
- *It's compulsory the use of a battery charger properly studied for ENERGA batteries.*
- *The failure of the respect of the instructions for use, the service effected from NOT AUTHORIZED personnel , declares the warranty NO MORE VALID.*



Li-ion batteries disposal

The batteries signed with the recycling symbol must be treated from a separate collection of rubbish centre recognized from the recycling Agency.
The batteries must not be mixed together with domestic and industrial rubbish.



Use protective glasses in order to work with battery.



Not open or dismantle the battery.



Grant always a safety and strong installation. Handle with care during the transport.



Battery terminals are always under tension. Not place near metallic objects and not wear metallic objects like clocks, bracelets etc..



Do not use free flames or other ignition sources. Risk of Explosion and Fire.
In case of fire, it's necessary to use a dust class D fire-extinguisher.
Do not use water or CO2 fire-extinguisher



EXPLOSION OR FIRE DANGER. Do not charge over 14,5 Volt. Evoid short circuits, use insulating tools.



In normal conditions the contact with chemical compounds is impossibile. If the box of the battery is damaged do not touch the exposed parts.



In case of contact with chemical compounds, rinse immediately with deep water.

1.2. BATTERY IDENTIFICATION DATA

Li - Ion Battery Pack
Model: xx – xx
Product n°: 000000
Nominal value: 13,2V xx Ah
Vmax charge: 14,5 V
Imax charge: xx A
Discharge peak current: xxA



BATTERY IDENTIFICATION DATA ARE INDICATED ON A PLATE LOCATED ON ITS CASE. THE PICTURE SHOWS THE COMPOSITION OF THE IDENTIFICATION PLATE.

1.3. WARRANTY

The battery referred to this Manual, is guaranteed according to the law, effective from the date of invoice.

The Warranty is no more valid if :

- Terms for maintenance not respect (recharge).
- Terms for conservation e/o off duty not respected
- Damages due to a wrong use , to be more precise functioning limits overcoming (**see technical data schedule**)
- Deformation or breakage of the box.
- Opening of the box.
- Replacement of the screws present on the poles with others of different length.
- Routine service or maintenance effected from **NOT qualified personnel**.
- Use of battery charter / maintainers **NON APPROVED BY ENERGA** .

2. BATTERY FEATURES

ENERGA battery is composed by LiFePO4 technology cells, assembled in a aluminum / plastic box.

2.1. *NORMATIVE REFERENCES*

ENERGA battery is build in compliance with the following laws :

Electromagnetic compatibility : EN 50081-1:1992

Immunity standards for Commercial electronic Products: EN 50082-1:1997

Low voltage Directive : 2006/95/EC

European Standard low Vooltage Directive: EN 60950:2000

2.2. *TECHNICAL FEATURES AND DIMENSIONS*

Litio – Ion BATTERY	13 – 12 R 13- 12 PR
Nominal voltage	13,2 V
Nominal capacity	12,3 A/h
End-charge max voltage	14,5 V
End-charge min voltage	8 V
Discharge max current (5 secs)	600 Amp
Charge max current	48 Amp
Max working temperature	50°C
Weight (+/-)	2230 gr
Dimensions (A x B x H mm)	139x93x155

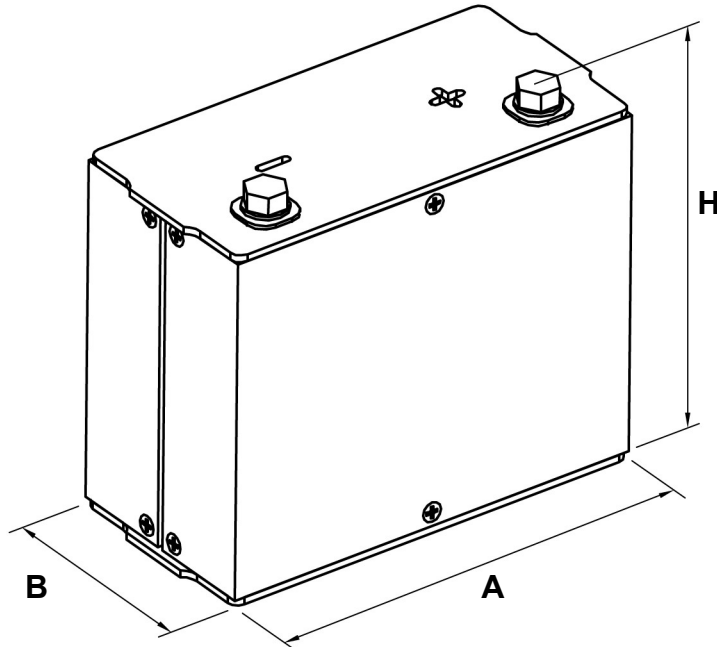

3. INSTALLATION

3.1. PRELIMINARY PROCEEDINGS

After the unpacking, check the battery in order to exclude possible mechanical damages. Don't use the battery if damaged. If you are not sure, pls. contact your supplier.

Verify the correct polarity of the whole plant that you will connect. The polarity is indicated on the connector of the battery through the following symbols :

+ positive **-** negative

3.2. PLACE OF INSTALLATION

Set the battery far from possible heat sources. Pls. look at the specifications contained in the chapter " TECHNICAL DATA " in order to find the allowed working temperature.

In case of installation on vehicles , the battery case must be suitably protected from water splashes , sunbeams and errant objects. Block the battery in a safe way, using, if necessary , some spongy material in order to fill the box.

3.3. CONNECTION

Use the cables for the appropriate section power connection. We advice to connect before the first negative pole and then the positive one.

IF NOT PRESENT, PUT A FUSE WITH AN APPROPRIATE VALUE BETWEEN THE BATTERY AND THE PLANT.

IT'S NOT ALLOWED THE REPLACEMENT OF THE SCREWS PRESENT ON BATTERY POLES WITH OTHER SCREWS OF DIFFERENT LENGHT.

3.4. BATTERY CHARGER

Like all the Liti technology batteries, ENERGA batteries must be charged with suitable battery chargers properly tested in the max current and max tension of end-charge.

The battery charger must work in a " CONSTANT CURRENT" regime that must not exceed the max allowed recharge current (look at the chapter TECHNICAL DATA **max charge current**), until the reaching of the "end-charge" tension (look at the chapter TECHNICAL DATA **max end-charge tension**) and go on with a " CONSTANT CURRENT" regime until the natural zeroing of the supplied current.

Moreover, in order to gain a longer life for battery we advice to charge it with a current not over the capacity declared from the battery (for example on the model 13-5° the capacity is 5 A/h and so you need to charge it with not more than 5 Ampere).

4. MAINTENANCE

The only maintenance needed from battery is the visual control of the connections on poles that haven't to be slow or oxidized.

4.1. MAINTENANCE e/o PRESERVATION

For vehicle stop period **over than 1 week**, being however a little absorption of current from junction box, anti-theft device etc.. , you need to maintain the battery charged, using the appropriate maintainers (look at the chapter **BATTERY CHARGERS**) because the **little** Liti batteries, damaged seriously themselves in case of excessive discharge (tension lower than 8 Volt).